



# Obsolescence Notice

This product is obsolete.

This information is available for your convenience only.

For more information on Zarlink's obsolete products and replacement product lists, please visit

[http://products.zarlink.com/obsolete\\_products/](http://products.zarlink.com/obsolete_products/)

**Features**

- Dual independent PLL frequency synthesisers in a single package, optimised for double conversion cable tuners, offering improved application
- 2.2GHz up-synthesiser optimised for low phase noise up to comparison frequencies of 4MHz
- 1.3GHz down-synthesiser optimised for low phase noise AND small step size
- Common reference oscillator and divider with independently selectable ratios for each synthesiser
- 10:1 programmable charge pump current ratio in up synthesiser
- 3-Wire bus programmable, each synthesiser independently addressable
- Low power consumption, typ 100mW at 5V
- ESD protection, (Normal ESD handling procedures should be observed)

**Applications**

- TV, VCR, and cable tuning systems

DS5076

ISSUE 1.6

October 1999

**Ordering Information**  
SP5848/KG/QP1S  
SP5848/KG/QP1T

**Description**

The SP5848 is a dual PLL frequency synthesizer controlled by a 3-wire bus optimised for application in double conversion tuners.

Each synthesiser loop within the SP5848 is independently addressable and contains an RF programmable divider, phase/frequency detector and charge pump/loop amplifier section; a common reference frequency oscillator and divider chain is provided, whose ratios for each loop are independently programmable.

Both synthesisers are optimised for low phase noise performance and in addition synthesiser 2 is capable of operation with a low comparison frequency.

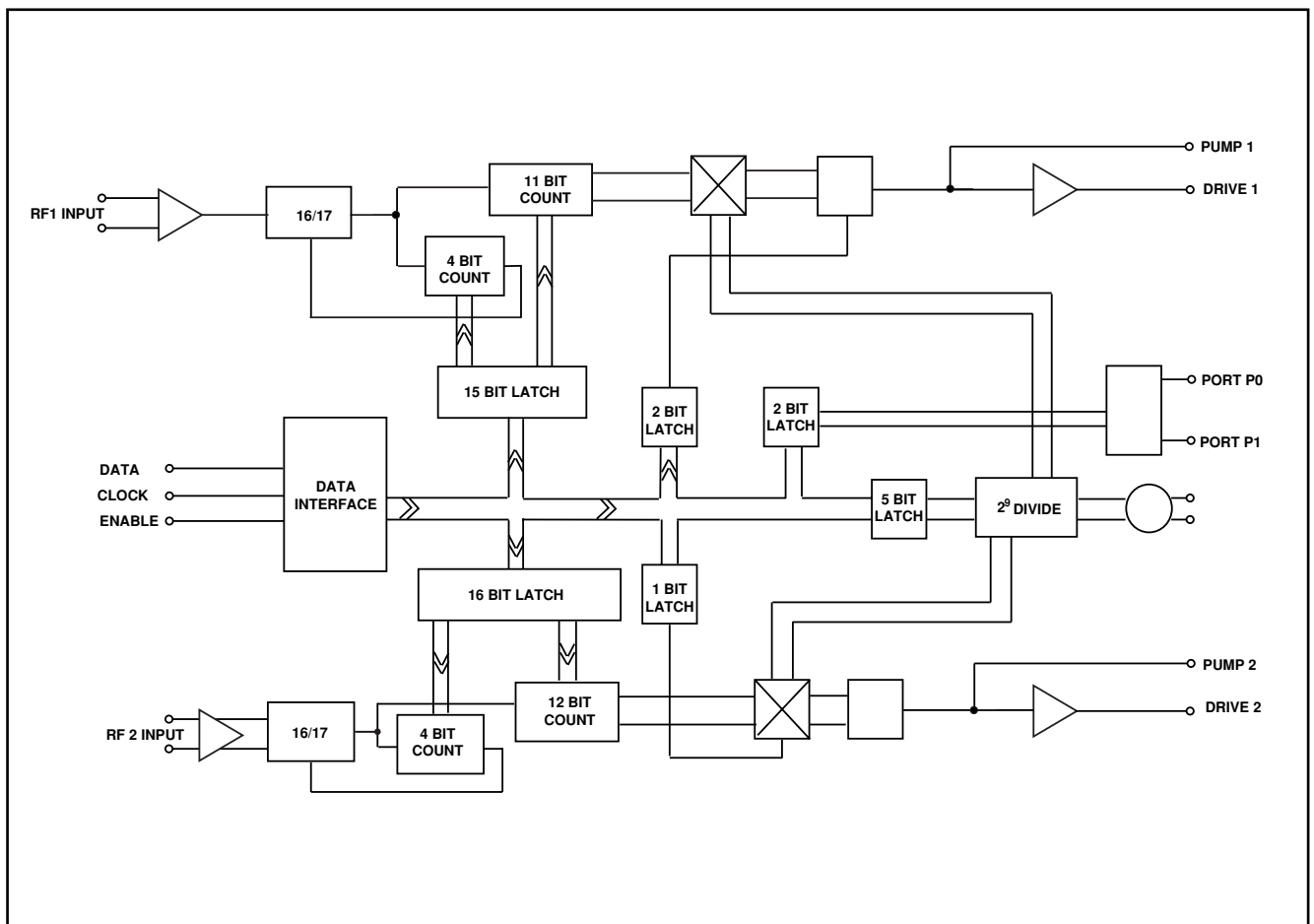

**Figure 1 - Block Diagram**

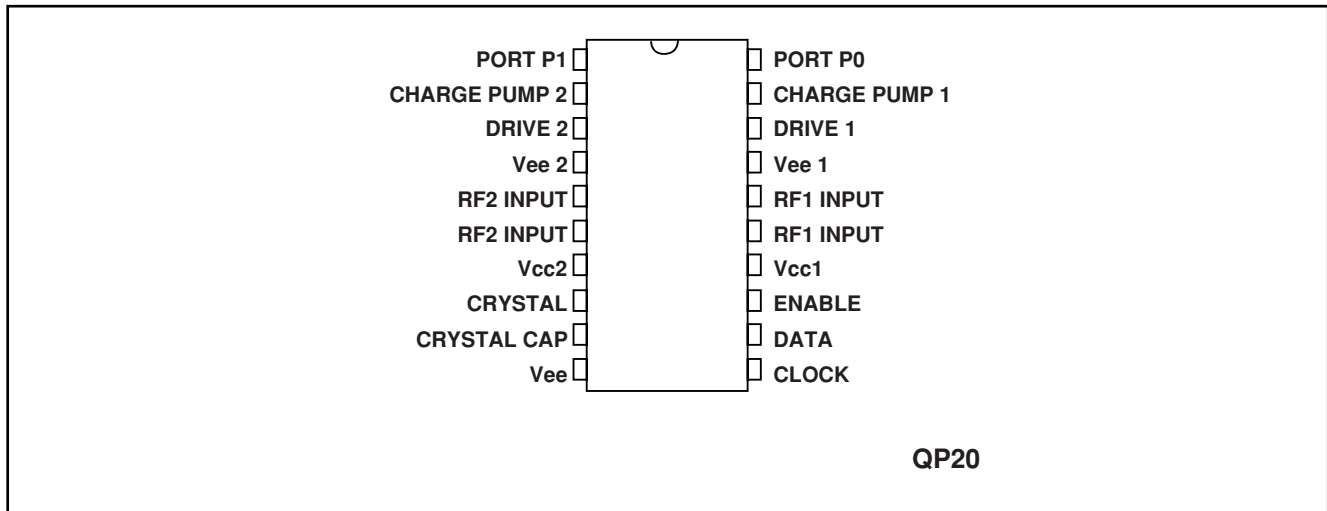

**Figure 2 - Pin Connections**

**Electrical Characteristics**

$T_{amb} = -40^{\circ}C$  to  $+80^{\circ}C$ ,  $V_{cc} = 4.5$  to  $5.5$  V, These characteristics are guaranteed by either production test or design. They apply within the specified ambient temperature and supply voltage unless otherwise stated.

Characteristic	Pin	Value			Units	Conditions
		Min	Typ	Max		
Supply voltage	7, 14	4.5		5.5	V	
Supply current			18	22	mA	
<b>Synthesiser 1 (UP)</b>						
RF1 input voltage	15,16	40		300	mV <sub>rms</sub>	80 -2200MHz
RF1 input impedance	15,16					See Figure 4
RF1 division ratio		240		32767		
Reference division 1 ratio						See Table 1
Comparison frequency 1				4	MHz	
Equivalent phase noise at phase detector 1			-148		dBc/Hz	SSB, within loop bandwidth, all comparison frequencies
Charge pump 1 output current	19					See Table 3
Charge pump 1 output leakage	19		±3	±10	nA	V <sub>pin 19</sub> =2V
Charge pump 1 drive output current	18	0.5			mA	V <sub>pin 18</sub> = 0.7V

**Electrical Characteristics (continued)**

$T_{amb} = -40^{\circ}\text{C}$  to  $+80^{\circ}\text{C}$ ,  $V_{cc} = 4.5$  to  $5.5$  V, These characteristics are guaranteed by either production test or design. They apply within the specified ambient temperature and supply voltage unless otherwise stated.

Characteristic	Pin	Value			Units	Conditions
		Min	Typ	Max		
<b>Synthesiser 2 (DOWN)</b>						
RF2 input voltage	5,6	30		300	mV <sub>rms</sub>	80 -1300MHz
RF2 input impedance	5,6					See Figure 5
RF2 division ratio		240		65535		
Reference division 2 ratio						See Table 2
Comparison frequency 2		16.25		4000	KHz	Phase noise degrades above 250KHz
Equivalent phase noise at phase detector 2			-144		dBc/Hz	SSB, within loop bandwidth, all comparison frequency up to 250KHz
Charge pump 2 output current	2					See Table 4
Charge pump 2 output leakage	2		±3	±10	nA	Vpin 2=2V Vpin2 = 2V
Charge pump 2 drive output current	3	0.5			mA	Vpin 3 = 0.7V
<b>Data, clock and enable</b>	12,11,13					
Input high voltage		3		Vcc	V	All input conditions
Input low voltage		0		0.7	V	
Input current hysteresis		-10	0.8	10	µA	
Clock rate	11			500	KHz	
Bus timing -						
Data set up		300			ns	
Data hold		600			ns	
Enable setup		300			ns	
Enable hold		600			ns	
Clock to enable		300			ns	
<b>Reference Oscillator</b>						
Crystal frequency	8, 9	2		16	MHz	See Figure 6 for application
External reference input frequency	8	2		20	MHz	Sinewave coupled through 10nF blocking capacitor
External reference drive	8	0.2		0.5	Vpp	Sinewave coupled through 10nF blocking capacitor
Outputs ports P0 - P1 sink current	1, 20	2			mA	See note 1 Vport = 0.7V
leakage current				10	µA	Vport = Vcc

Note 1 Output ports high impedance on power up, with data, clock and enable at logic 0

## Absolute maximum Ratings

All voltages referred to Vee at 0V

Characteristic	Value		Units	Conditions
	Min	Max		
Supply voltages	-0.3	7	V	
RF1 input voltage		2.5	Vp-p	Differential
RF2 input voltage		2.5	Vp-p	Differential
All I/O ports DC offset	-0.3	Vcc+0.3	V	
Storage temperature	-55	+125	°C	
Junction temperature		150	°C	
Package thermal resistance				
chip to ambient		100	°C/W	
chip to case		30	°C/W	
Power consumption with all Vcc =5.5V		121	mW	All ports off
ESD protection	2		kV	Mil std 883 latest revision method 3015 class 1

## Functional Description

The SP5848 contains two PLL frequency synthesiser loops, each independently programmable from a 3-wire bus. The device is optimised for application in double conversion tuners where synthesiser 1 would form part of the upconverter and synthesiser 2 part of the down converter. Both loops are optimised for application in low phase noise loops and furtherly synthesiser 2 offers low comparison frequencies. A block diagram is contained in Figure 1.

The device is programmed via a 3-wire bus where data is fed on serial data and clock lines and is gated by an enable line. Figure 3 indicates the format of the data. The sequence and timing of data load is described below in 'programming mode' description. Each synthesiser is independently addressable and is defined by the LSB bit within the data transmission.

A common reference frequency source and reference divider is used to derive the comparison frequency for both PLL loops. The reference division ratio is programmable via the data bus as defined in Tables 1 and 2.

The charge pump current for each loop is also programmable via the data bus as defined in Tables 3 and 4

Two switching ports are provided to control switching functions within the tuner. These ports also access test signals within the PLL as defined in Figure 7. Ports power up in high impedance state.

## Programming Mode

The SP5848 is designed to be programmed from a standard 3-wire bus consisting of clock, data and enable, where the serial clock and data lines can be shared with other devices and the enable line is a unique line for individual device selection. To simplify programming each synthesiser is independently addressed, with the required loop being selected by the LSB bit, which functions as the address, therefore to fully program the device two complete data transmissions must be sent.

The data format for each transmission is contained in Figure 3.

Test modes as described in Figure 7, can be invoked by setting bit T0 in synthesiser 2 data word to a '1' and sending control data for bits T1-T2. In normal operation where T0 is set to a '0' bits T1 and T2 do not need to be transmitted

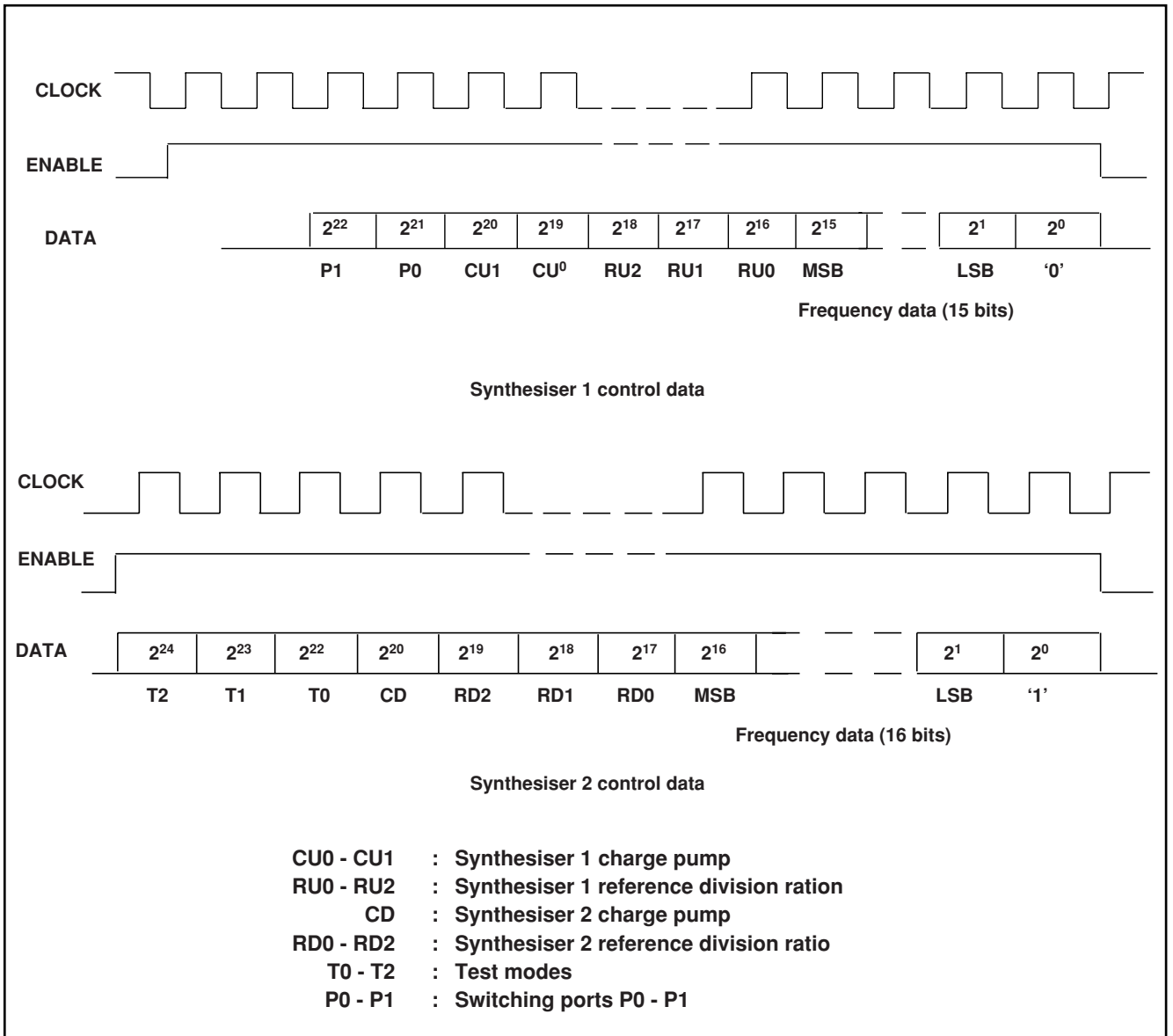

Figure 3 - Control data

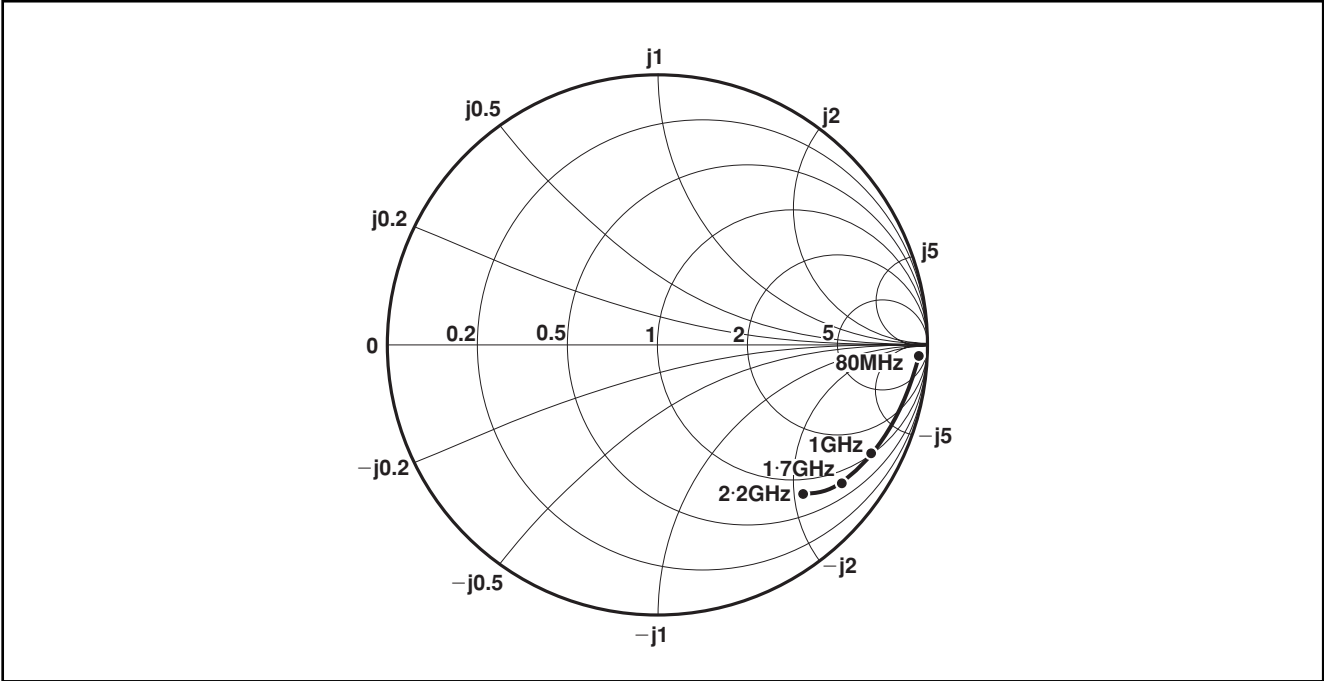

Figure 4 - Synthesiser 1 RF input impedance

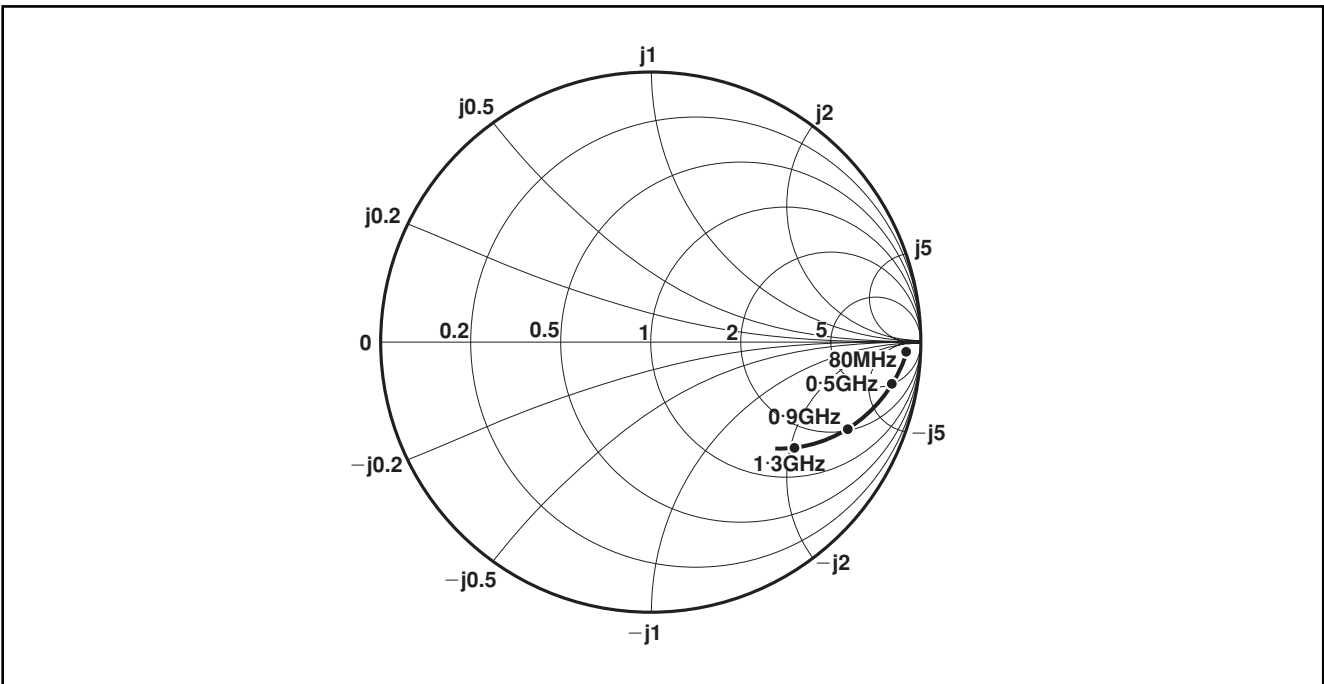

Figure 5 - Synthesiser 2 RF input impedance

RU2	RU1	RU0	Ratio
0	0	0	2
0	0	1	4
0	1	0	8
0	1	1	16
1	0	0	32
1	0	1	64
1	1	0	128
1	1	1	256

**Table 1 - Synthesiser 1 reference division ratio**

RU2	RU1	RU0	Ratio
0	0	0	4
0	0	1	8
0	1	0	16
0	1	1	32
1	0	0	64
1	0	1	128
1	1	0	256
1	1	1	512

**Table 2 - Synthesiser 2 reference division ratio**

CU1	CU0	Current (typical in mA)
0	0	0.12
0	1	0.26
1	0	0.55
1	1	1.2

**Table 3 - Synthesiser 1 charge pump current**



CD	Current (typical in mA)
0	0.05
1	0.2

**Table 4 - Synthesiser 2 charge pump current**

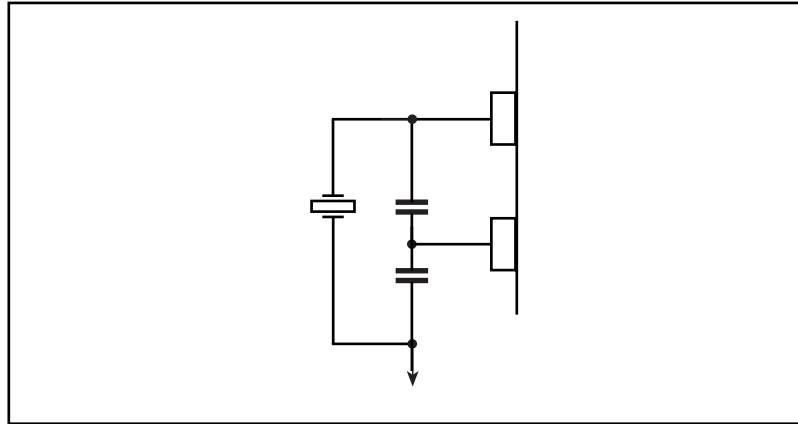

**Figure 6 - Crystal oscillator application**

T2	T1	T0	Functional Description
X	X	0	Normal operation
0	0	1	Both charge pumps in sink mode
0	1	1	Both charge pumps in source mode
1	0	1	Port P1 = Fcomp1, P0 = Fcomp2 and charge pumps disabled
1	1	1	Port P1 = (Fpd1)/2, P0 = (Fpd2)/2

X = dont care

**Figure 7 - Test modes**



**For more information about all Zarlink products  
visit our Web Site at  
[www.zarlink.com](http://www.zarlink.com)**

Information relating to products and services furnished herein by Zarlink Semiconductor Inc. or its subsidiaries (collectively "Zarlink") is believed to be reliable. However, Zarlink assumes no liability for errors that may appear in this publication, or for liability otherwise arising from the application or use of any such information, product or service or for any infringement of patents or other intellectual property rights owned by third parties which may result from such application or use. Neither the supply of such information or purchase of product or service conveys any license, either express or implied, under patents or other intellectual property rights owned by Zarlink or licensed from third parties by Zarlink, whatsoever. Purchasers of products are also hereby notified that the use of product in certain ways or in combination with Zarlink, or non-Zarlink furnished goods or services may infringe patents or other intellectual property rights owned by Zarlink.

This publication is issued to provide information only and (unless agreed by Zarlink in writing) may not be used, applied or reproduced for any purpose nor form part of any order or contract nor to be regarded as a representation relating to the products or services concerned. The products, their specifications, services and other information appearing in this publication are subject to change by Zarlink without notice. No warranty or guarantee express or implied is made regarding the capability, performance or suitability of any product or service. Information concerning possible methods of use is provided as a guide only and does not constitute any guarantee that such methods of use will be satisfactory in a specific piece of equipment. It is the user's responsibility to fully determine the performance and suitability of any equipment using such information and to ensure that any publication or data used is up to date and has not been superseded. Manufacturing does not necessarily include testing of all functions or parameters. These products are not suitable for use in any medical products whose failure to perform may result in significant injury or death to the user. All products and materials are sold and services provided subject to Zarlink's conditions of sale which are available on request.

Purchase of Zarlink's I<sup>2</sup>C components conveys a licence under the Philips I<sup>2</sup>C Patent rights to use these components in and I<sup>2</sup>C System, provided that the system conforms to the I<sup>2</sup>C Standard Specification as defined by Philips.

Zarlink, ZL and the Zarlink Semiconductor logo are trademarks of Zarlink Semiconductor Inc.

Copyright Zarlink Semiconductor Inc. All Rights Reserved.

**TECHNICAL DOCUMENTATION - NOT FOR RESALE**

---